

Parts

Item	Req.	Name Part.	No.
1	9	Pulley	LA-3687
2	2	Rod. Guide	K-6933
3	2	Slide	K-6937
4	2	Rod. Guide	K-7407
5	2	Rod	LB-1326
6	1	Shaft	LB-1328
7	4	Spring	LB-1336
8	2	Support Roller	K-6930
9	1	Base	I-9889
10	2	Support	IA-2399
11	2	Roll Pin	281.072

Item	Req.	Name Part.	No.
12	2	Rod	LB-1325
13	1	Pipe	LB-1329
14	1	Rod. Spool	K-6934
15	4	Bumper	081.013
16	4	Spacer	632.143
17	4	Follower Corn	026.001
18	2	Block Bearing	K-6936
19	1	Rod	LB-1323
20	1	Block	LB-1327
21	1	Bar	LB-1330

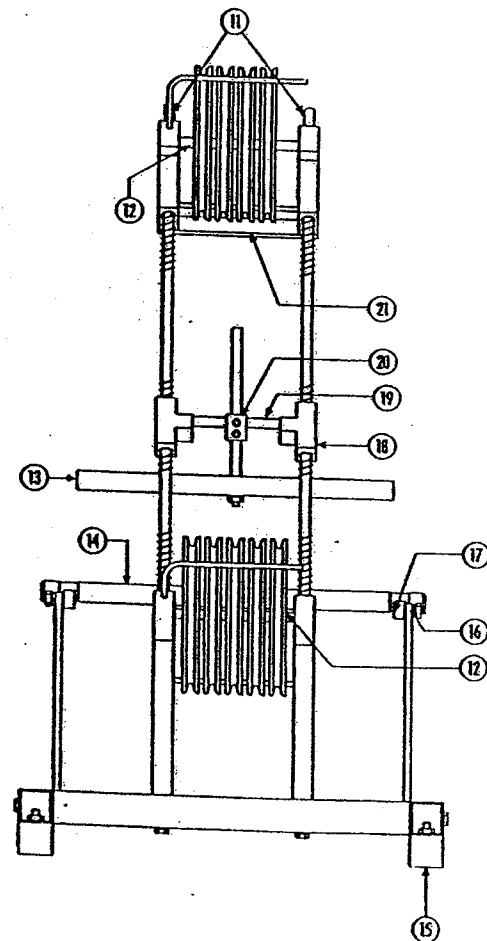
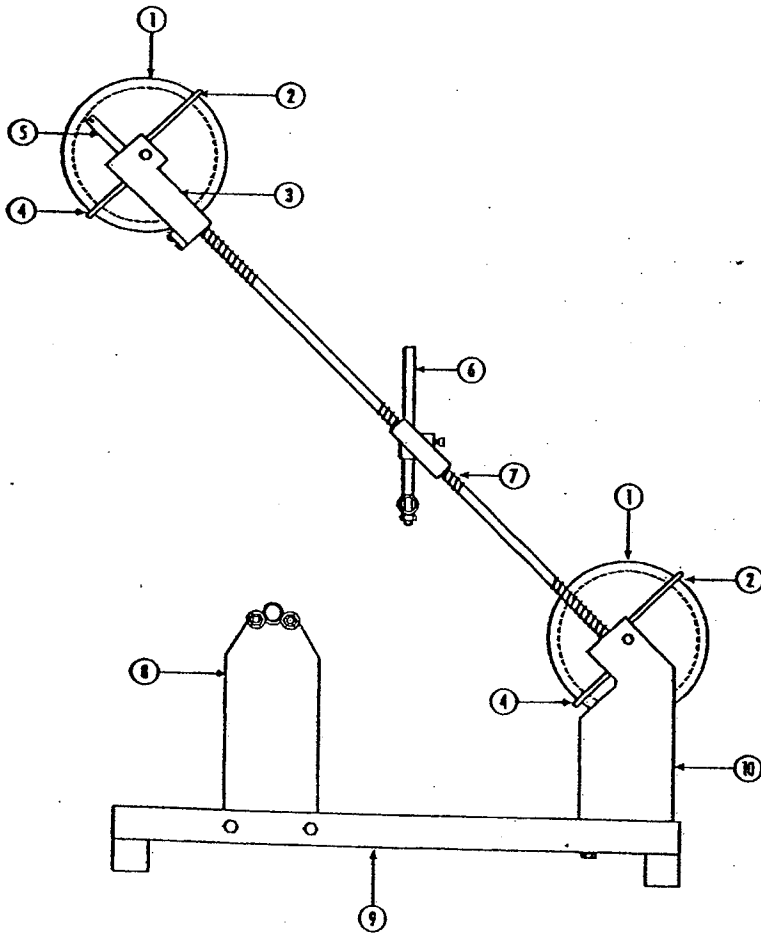

Warranty limited solely to repair or replacement; no warranty of merchantability, fitness for a particular purpose or consequential damages.

ARTOS
ENGINEERING COMPANY

21605 Gateway Court
Brookfield, WI 53045
PH 262-252-4545
www.artosnet.com

Premium Wire De-Reeler

For use with any wire processing equipment and 6" to 16" Dia. Wire Reels

■ Installation:

1. The Premium Wire De-Reeler is packaged in two parts. Use 1/4-20 hex head screws, 2" long, provided with De-Reeler to bolt the two assemblies together. (see below)
2. Remove centering rod from corrugated box insert and place it in the center of the wire reel to be used.

■ Use

1. Place wire reel and centering rod on to De-Reeler stand.
NOTE: Wire must de-reel from top of wire reel.
2. Feed wire around pulleys. (see below)
NOTE: Large reels require all pulleys, small reels may require only 1 or 2 pulleys.
3. Adjust stop rod to contact outer rim of reel. Enough force should be applied to the reel rim to prevent excessive overspin.

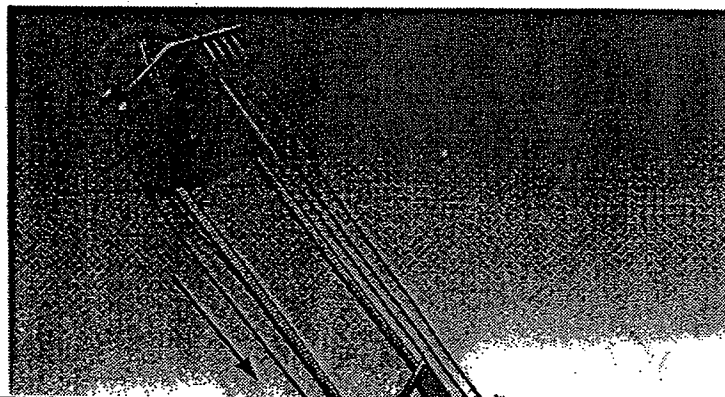

Stop Rod

Assemble here with
screws provided

To wire processing
equipment