

# CS327 Blades for 2 blade cutterhead

REV 27 04/03/2017

## Table of Contents

- Wire cut off blades..... 2
  - Standard cutoff blade ..... 2
  - Wide cutoff blade ..... 3
  - Interlocking blade assembly ..... 4
  - Carbide insert blade assembly for steel cable ..... 5
  - Flat material cutoff blade..... 6
  - Pinch blade assembly for brake line ..... 7
- Wire stripping blades ..... 8
  - Universal V style stripping blades ..... 8
  - True radius style stripping blades ..... 8
  - Stripping depth stop ..... 11
  - Tangent radius style stripping blades ..... 13
  - Parallel cord stripping blades..... 14
  - Oval strip blades..... 15

Dimensions on blade sketches are in inches.

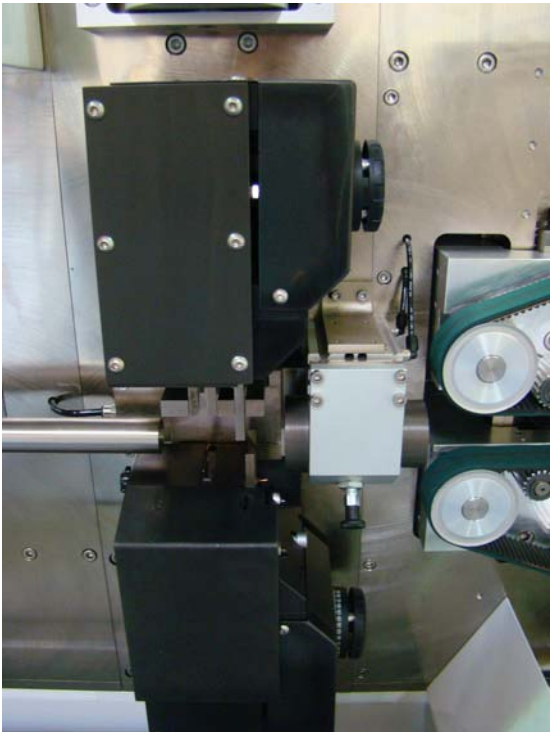

View of 2 blade cutterhead

# Wire cut off blades

## Standard cutoff blade

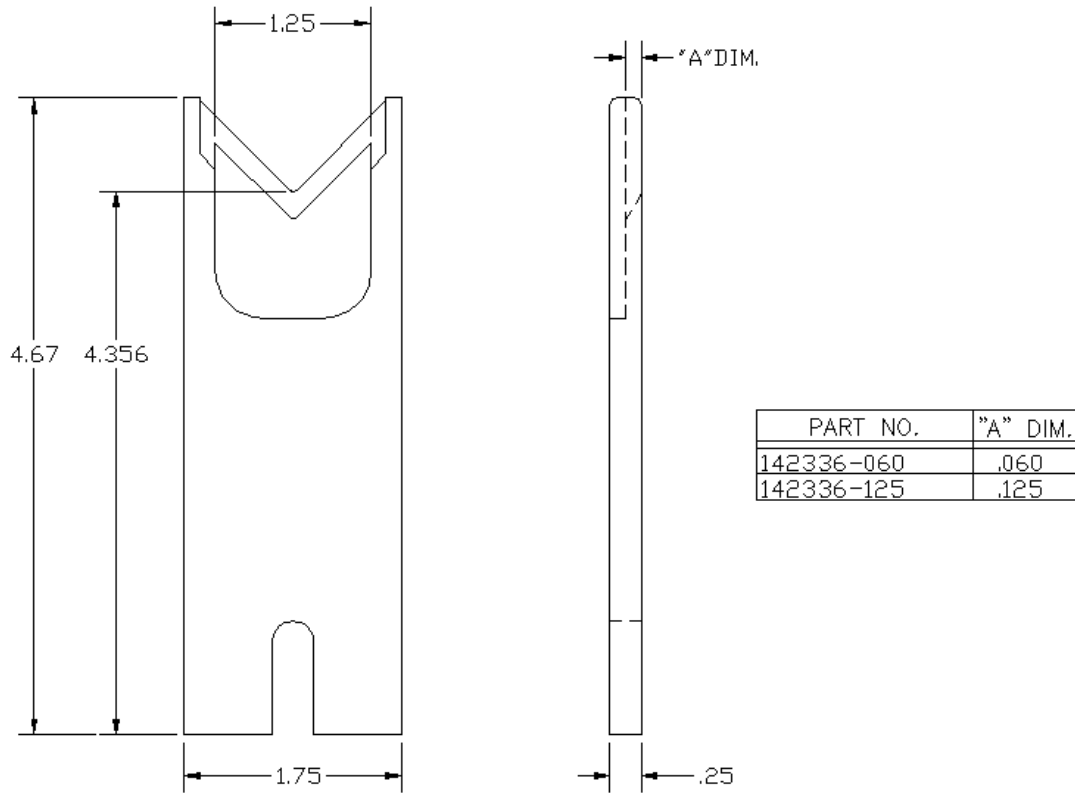

**142336-125** Wire cut off blade. This is the standard blade for all general cutting.

**142336-125TC** Wire cut off blade, Tin Coated. This is the standard blade for all general cutting.

**124264-2.0** Wire cut off blade. This is specifically for cutting aluminum wire so it does not gall and bind. It is a replacement for 142336-125 copper cutting blade.

**142336-060** Wire cut off blade. This blade has an extra deep relief cut out so the wire strands do not cone out as noticeably as with the -125 blade, and the blade will cut through easier. It is mainly for larger diameter wires with fine stranding.

## Wide cutoff blade

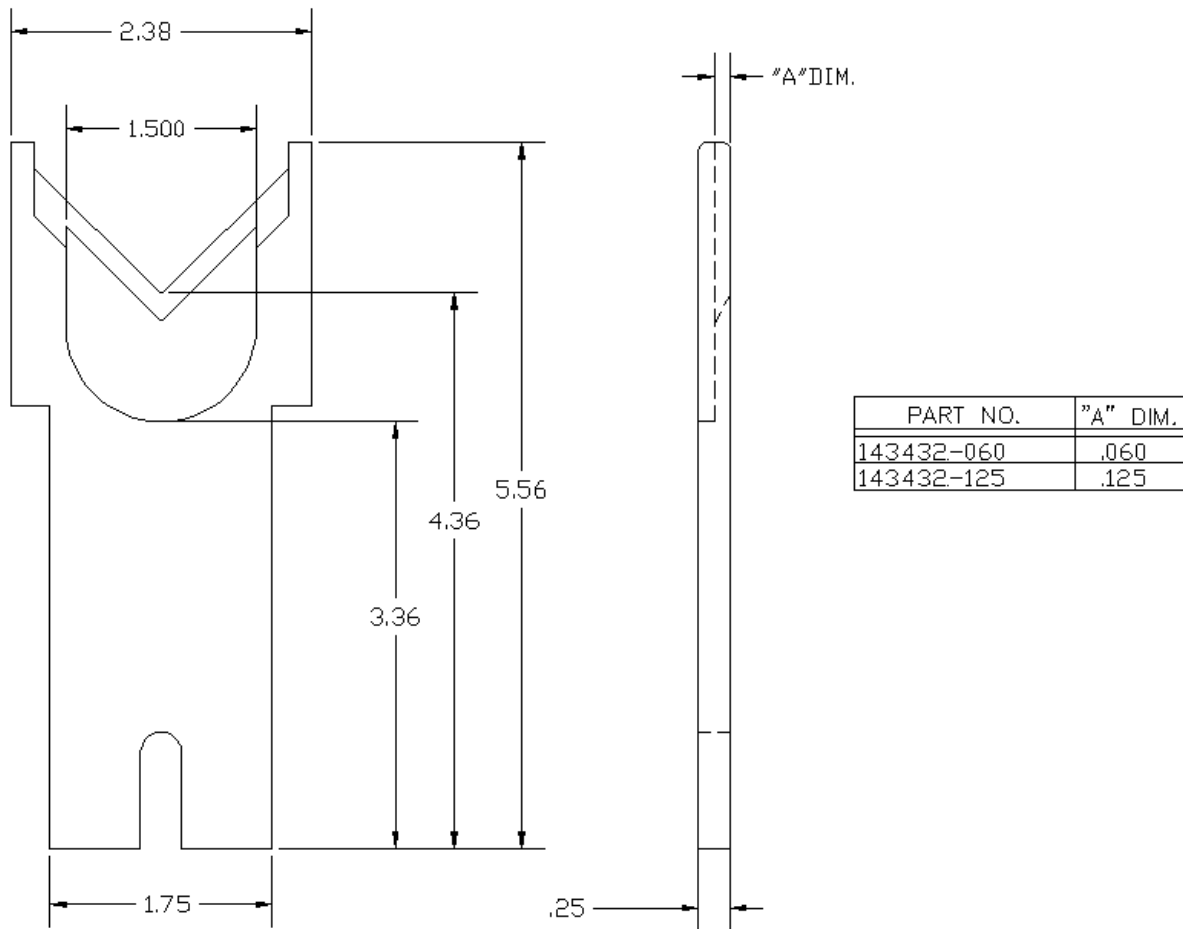

**143432-125** Wire cut off blade. When using this blade you must also use blade guide **143433**.

**143432-060** Wire cut off blade. This blade is has an extra deep relief cut out so the wire strands do not cone out as noticeably as with the -125 blade, and the blade will cut through easier. It is mainly for larger diameter wires with fine stranding. When using this blade you must also use blade guide **143433**.

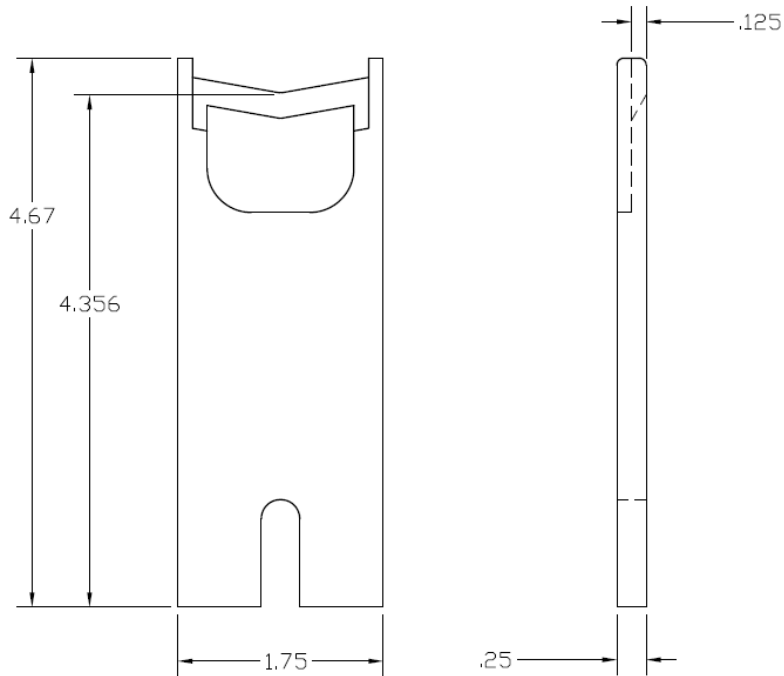

**143059** Flat wire cut off blade.

***Interlocking blade assembly***

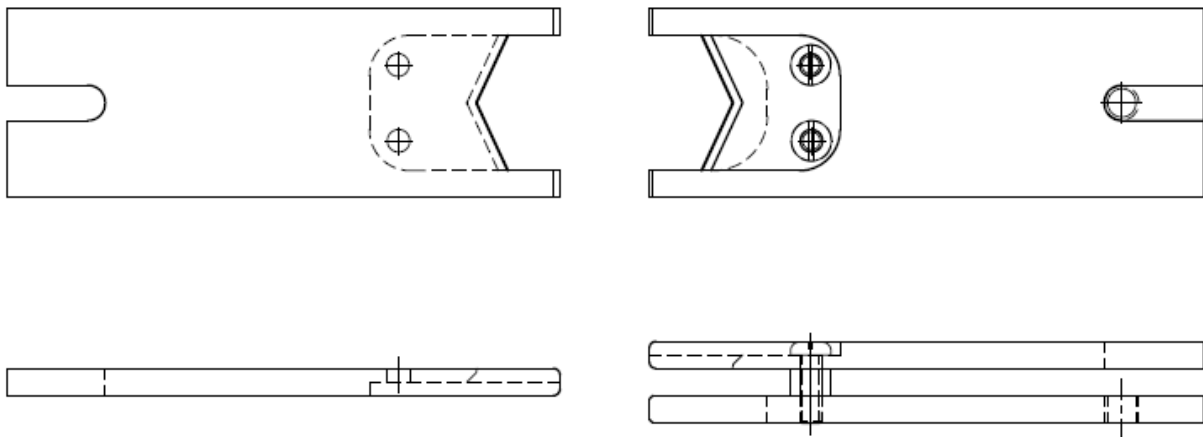

**5-142978** Interlocking cut blade assembly. This type of blade style is used for wire that is hard to cut. You would use this when with regular blades the strands of the wire are actually bending and folding in between the cut blades. The regular blades may even be chipping due the strands sliding over the cut edge and going in between the blades.

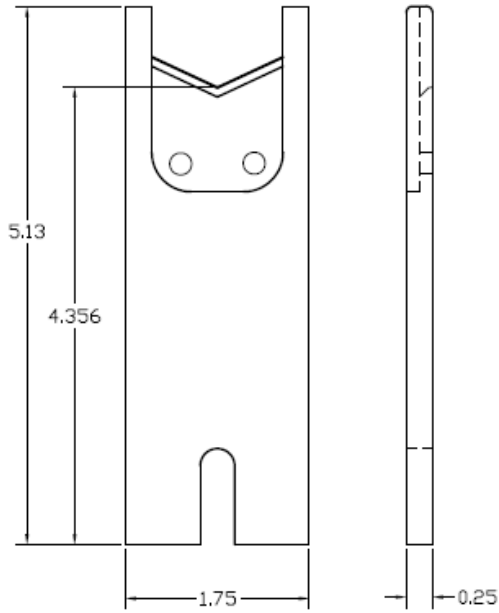

**123634** Replacement cut blade, used in assembly 5-142978

***Carbide insert blade assembly for steel cable***

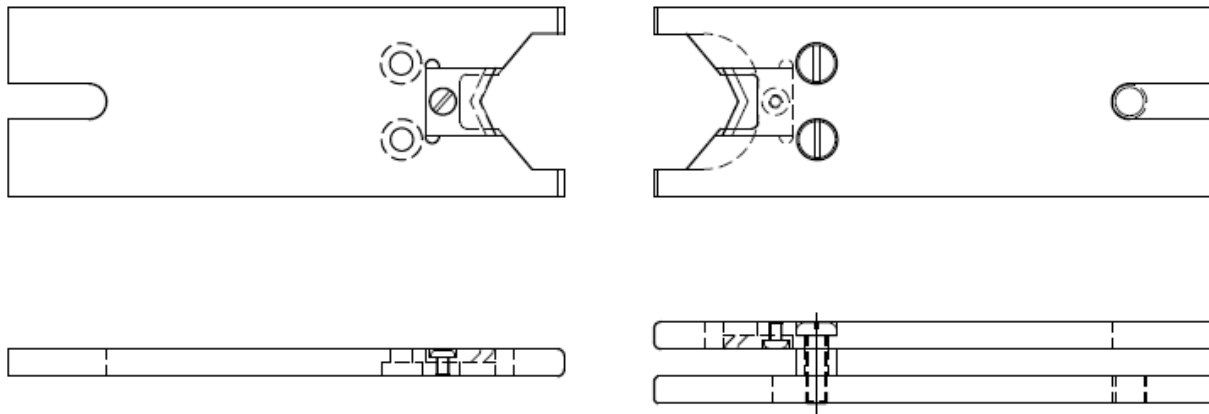

**5-143296** Interlocking blade assembly with carbide cutting insert for cutting steel cable

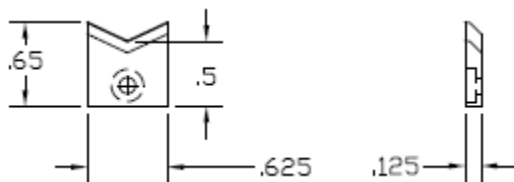

**143216** Replacement steel cutting carbide insert used in assembly 5-143296

**146435** Replacement stainless steel cutting carbide insert used in assembly 5-143296

## ***Flat material cutoff blade***

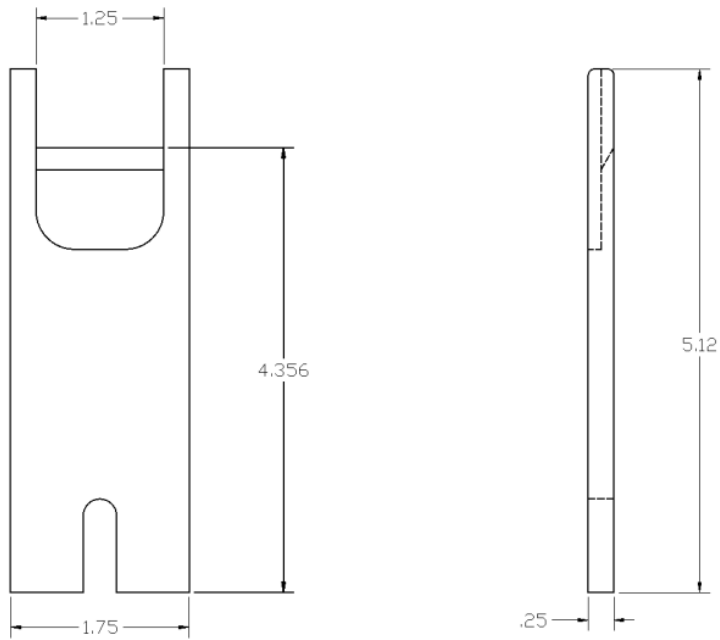

**123722** Collinear angle cut-off. Sharp edges cut by shearing action. This class of blade was designed to allow multiple conductor wire to be processed without deforming the wire. The main advantage of this class is the ability to process many different wire gauges with the same blades.

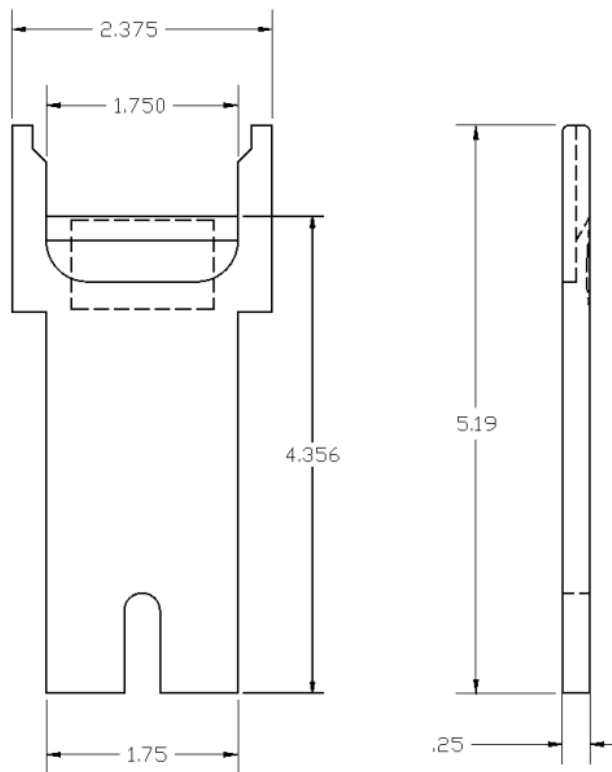

**124845-125** Wire cut off blade. When using this blade you must also use blade guide **143433**.

**124845-060** Wire cut off blade. This blade is has an extra deep relief cut out so the wire strands do not cone out as noticeably as with the -125 blade, and the blade will cut through easier. It is mainly for larger diameter wires with fine stranding. When using this blade you must also use blade guide **143433**.

***Pinch blade assembly for brake line***

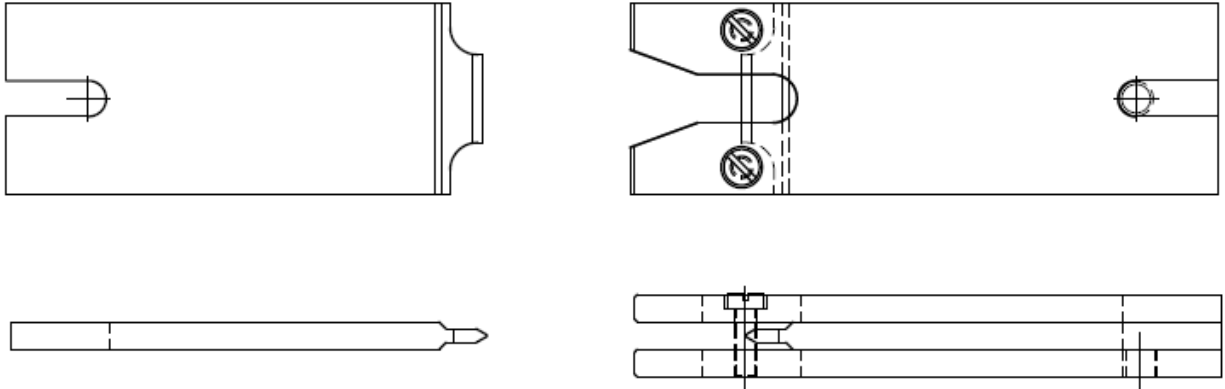

**5-144862** Interlocking pinch blade assembly. This blade was designed specifically for cutting spiral wound housings, such as brake cable housing.

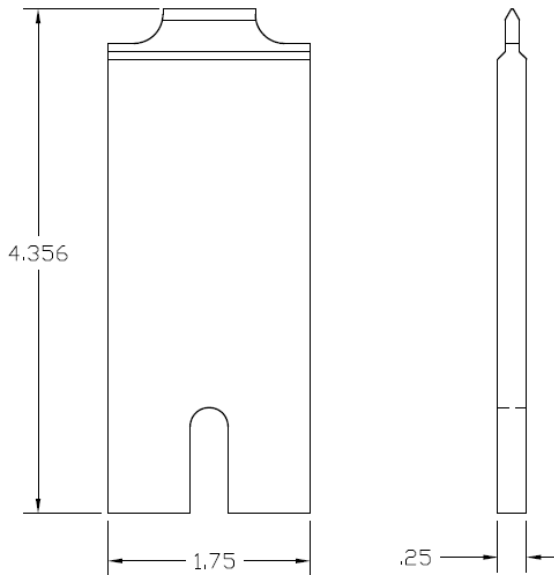

**144811** Replacement pinch blade, used in assembly 5-144862

# Wire stripping blades

## Universal V style stripping blades

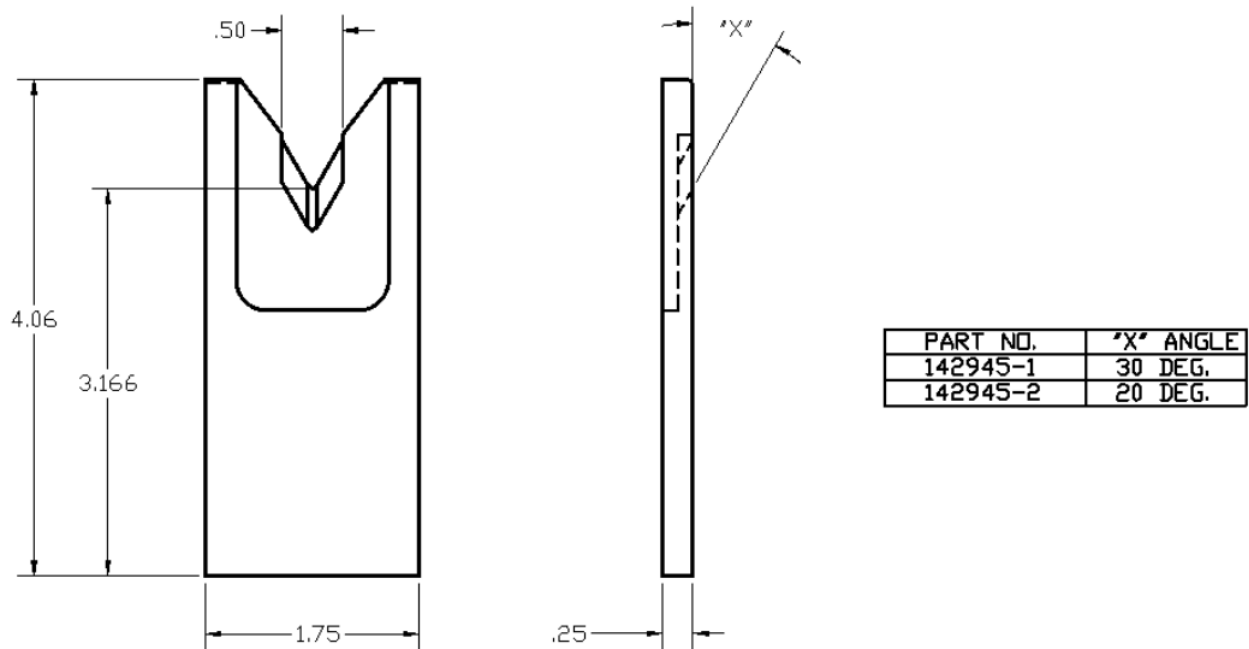

**142945-1** Strip blade "V" 30 degree.

**142945-2** Strip blade "V" 20 degree, the 20 degree edge has a steeper angle and will give a very clean cut. The downside is that they do not stay sharp as long as 30 degree would.

## True radius style stripping blades

The sharp edge is ground to a half circle whose radius approximates awg wire size. The entry angle lines intersect the half circle at the quadrant points. This type of blade, when closed, presents a true circle profile.

**Advantages:** this type of blade is excellent for precise and clean jacket removal because it combines the scissor-like shearing action of the by-pass blade with the exact hole profile matching a conductor gauge. Excellent for thin wall cross-link PVC and most rubbery or elastic insulations (thin or thick wall).

**Disadvantages:** shut height cannot be modified to process adjacent wire sizes. Off center wire condition has to be considered when choosing blade size.



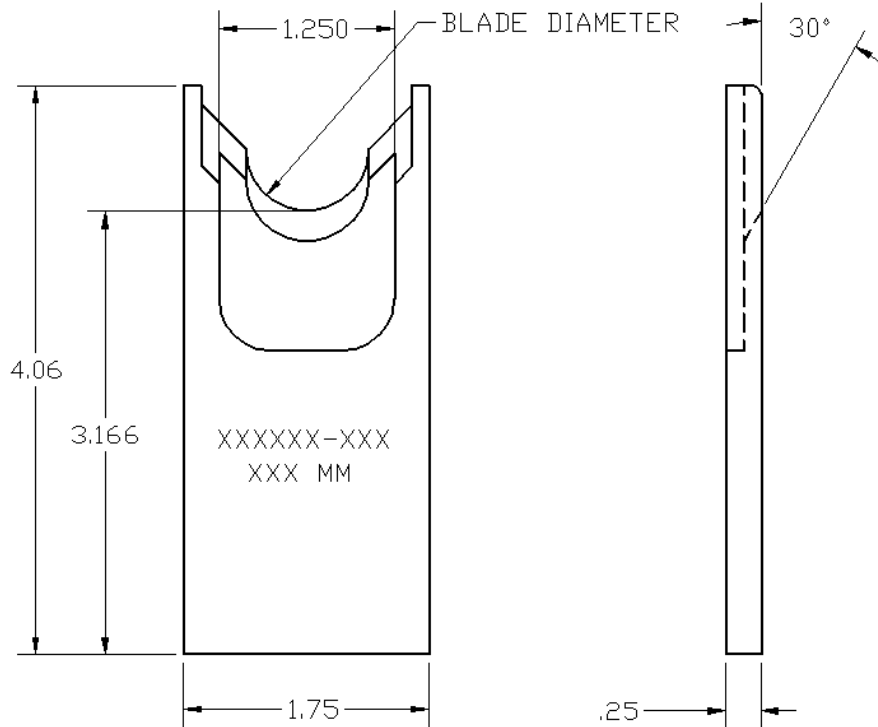

**142337-xxx** Strip blade, radius style 30 degree, the dash number is the diameter of the hole in the blade in inches. Example -028 is .028 inches

Dash #	millimeters				
-024	0.61	-230	5.84	-620	15.75
-031	0.78	-240	6.10	-640	16.26
-039	0.99	-260	6.60	-660	16.76
-047	1.19	-270	6.86	-680	17.27
-055	1.40	-280	7.11	-700	17.78
-062	1.57	-300	7.62	-720	18.29
-067	1.70	-320	8.13	-740	18.80
-070	1.78	-340	8.64	-760	19.30
-074	1.88	-350	8.89	-780	19.81
-078	1.98	-360	9.14	-800	20.32
-090	2.29	-370	9.40	-820	20.83
-102	2.59	-380	9.65	-840	21.34
-112	2.84	-400	10.16	-860	21.84
-125	3.17	-410	10.41	-880	22.35
-135	3.43	-420	10.67	-900	22.86
-140	3.56	-440	11.18	-920	23.37
-145	3.68	-460	11.68	-940	23.88
-150	3.81	-480	12.19	-960	24.38

-160	4.06	-500	12.70	-980	24.89
-170	4.32	-520	13.21	-1000	25.40
-175	4.45	-540	13.72	-1010	25.65
-200	5.08	-560	14.22	-1170	29.72
-210	5.33	-580	14.73		
-220	5.59	-600	15.24		

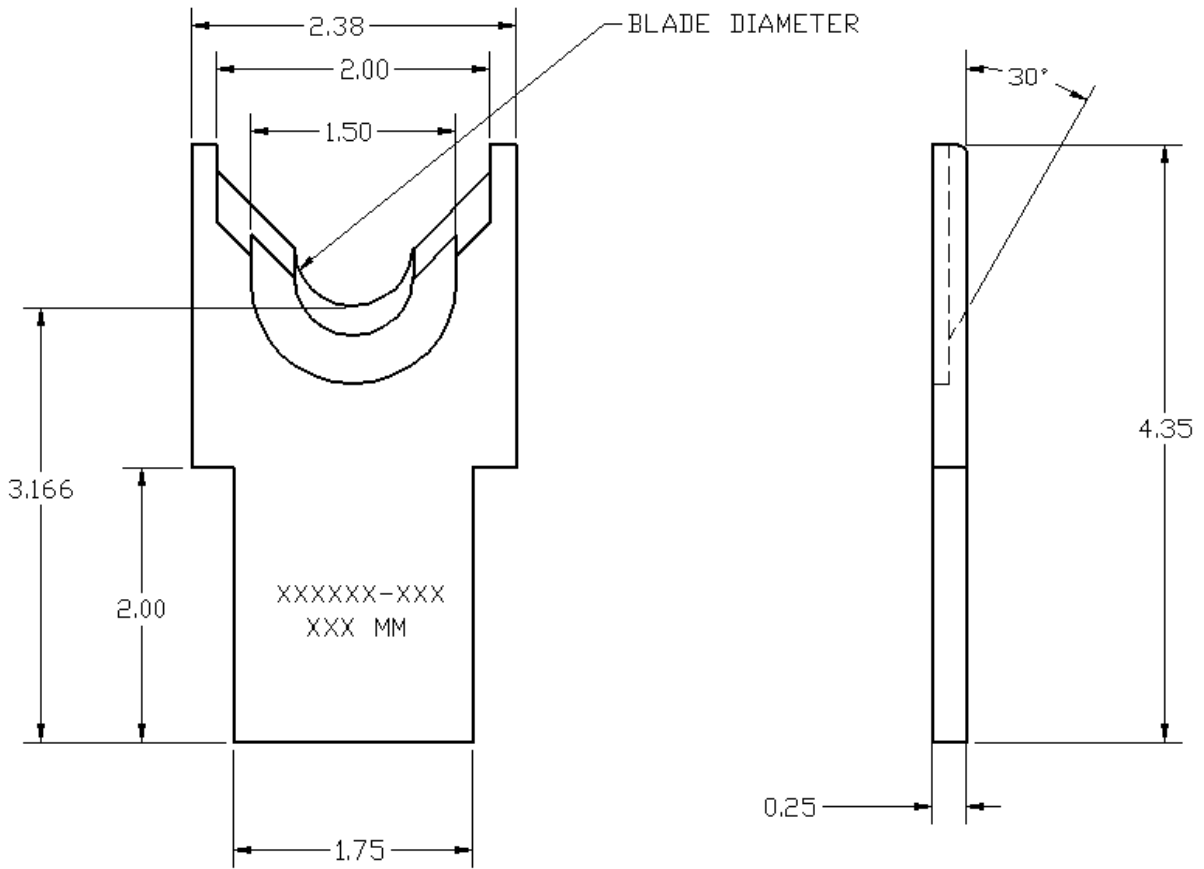

**146513-xxx** Strip blade, radius style 30 degree, the dash number is the diameter of the hole in the blade in inches. Example -028 is .028 inches

Dash #	millimeters				
-1000	25.40	-1160	29.46	-1320	33.53
-1020	25.91	-1180	29.97	-1340	34.04
-1040	26.42	-1200	30.48	-1360	34.54
-1060	26.92	-1220	30.99	-1380	35.05
-1080	27.43	-1240	31.50	-1400	35.56
-1100	27.94	-1260	32.00	-1420	36.07
-1120	28.45	-1280	32.51	-1440	36.58
-1140	28.96	-1300	33.02		

### ***Stripping depth stop***

This stop is normally used with true radius blades. It controls how deep the blade can penetrate into the insulation, it may also help prevent the blade from scrapping on the strands as the slug is pulled off. It is installed in the machine by installing this part in place of the spacer that is normally next to the stripping blade. An example of how it is mounted in the machine is shown at the right.

When using depth stop the machine must have the following 2 parts installed. These are not included on a standard CS327 machine

**146004** Slug knockout and manifold. For use when using cutting depth stops.

**5-146005** Slug shield for use this 146004 slug knockout.



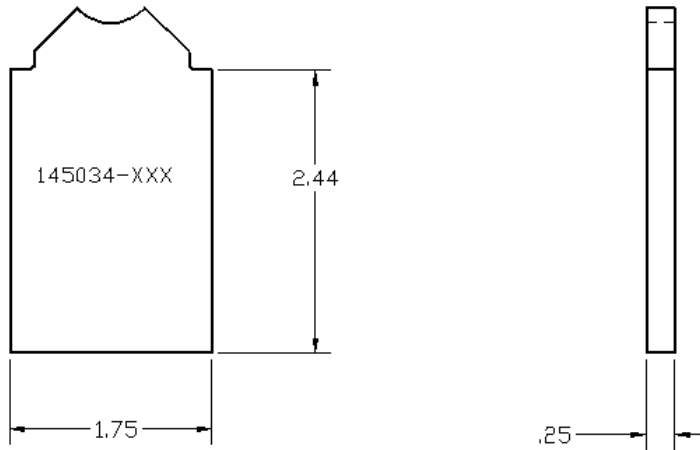

**145034-xxx** Depth stop, the stop must be selected according to the conductor diameter and the insulation diameter.

Dash #	Insulation diameter inch	Insulation diameter mm	Strip blade diameter inch	Strip blade diameter mm
-150	0.150	3.81	0.100	2.54
-182	0.182	4.62	0.108	2.74
-200	0.200	5.08	0.110	2.79
-236	0.236	5.99	0.160	4.06
-250	0.250	6.35	0.145	3.68
-290	0.290	7.37	0.176	4.47
-340	0.340	8.64	0.200	5.08
-342	0.342	8.69	0.220	5.59
-380	0.380	9.65	0.260	6.60
-420	0.420	10.67	0.300	7.62
-433	0.433	11.00	0.320	8.13
-450	0.450	11.43	0.330	8.38
-490	0.490	12.45	0.360	9.14
-510	0.510	12.95	0.400	10.16
-530	0.530	13.46	0.370	9.40
-600	0.600	15.24	0.400	10.16
-620	0.620	15.75	0.450	11.43
-680	0.680	17.27	0.540	13.72
-720	0.720	18.29	0.572	14.53
-820	0.820	20.83	0.650	16.51
-824	0.820	20.83	0.200	5.08

## Tangent radius style stripping blades

The sharp edge is ground to an arc whose radius approximates awg wire size. The entry angle lines meet the arc at a tangent point. This type of blade, when closed, presents a diamond shaped edge profile.

Advantages: by adjusting cutter head shut height, (if insulation material and wall thickness allow), you can process adjacent wire extrusions. It also tips the slug less as it is pulled from the wire, sometimes reducing the amount of scrapping on the conductors.

Disadvantages: inadequate for processing thin wall and/or hard insulations such as cross-link or fiberglass jackets.

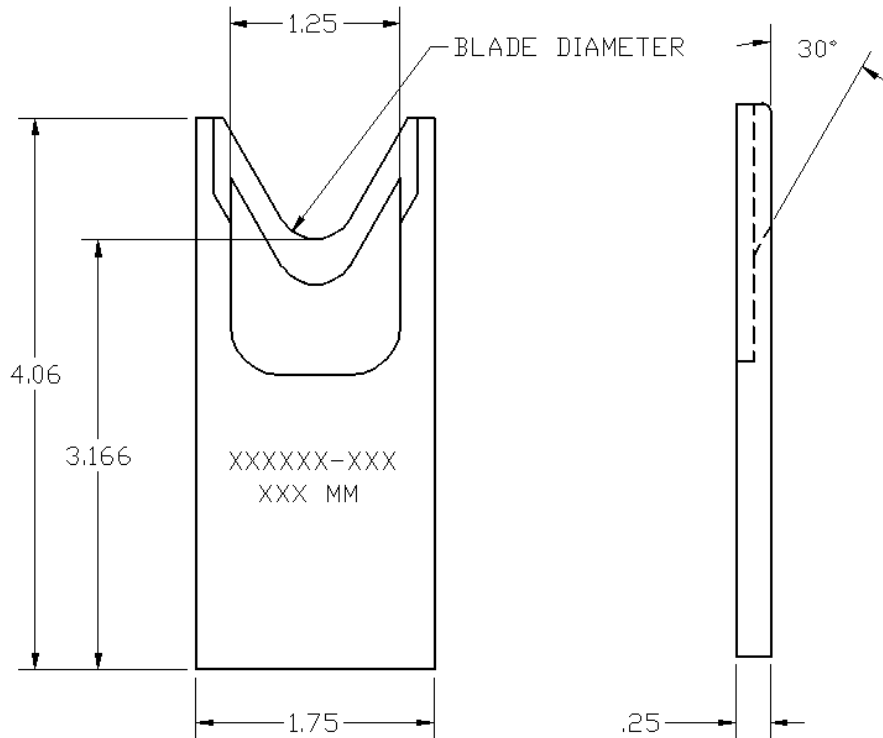

**143066-xxx** Strip blade, tangent radius style 30 degree. The dash number is the diameter of the hole in the blade in inches. Example -028 is .028 inches

Dash #	millimeters				
-024	0.61	-280	7.11	-660	16.76
-031	0.78	-300	7.62	-680	17.27
-039	0.99	-320	8.13	-700	17.78
-047	1.19	-340	8.64	-720	18.29
-055	1.40	-360	9.14	-740	18.80
-067	1.70	-380	9.65	-760	19.30
-078	1.98	-400	10.16	-780	19.81
-090	2.29	-420	10.67	-800	20.32
-102	2.59	-440	11.18	-820	20.83
-112	2.84	-460	11.68	-840	21.34
-125	3.17	-480	12.19	-860	21.84

-140	3.56	-500	12.70	-880	22.35
-150	3.81	-520	13.21	-900	22.86
-160	4.06	-540	13.72	-920	23.37
-175	4.45	-560	14.22	-940	23.88
-200	5.08	-580	14.73	-960	24.38
-220	5.59	-600	15.24	-980	24.89
-240	6.10	-620	15.75		
-260	6.60	-640	16.26		

### ***Parallel cord stripping blades***

These blades are for stripping 2 or more conductor flat cable. Special wire guides may be required to hold the wire flat as it runs through the machine. Typically each different type of cord needs a different blade size. Contact the Artos sales department for information on how to submit a sample wire for blade sizing and design.

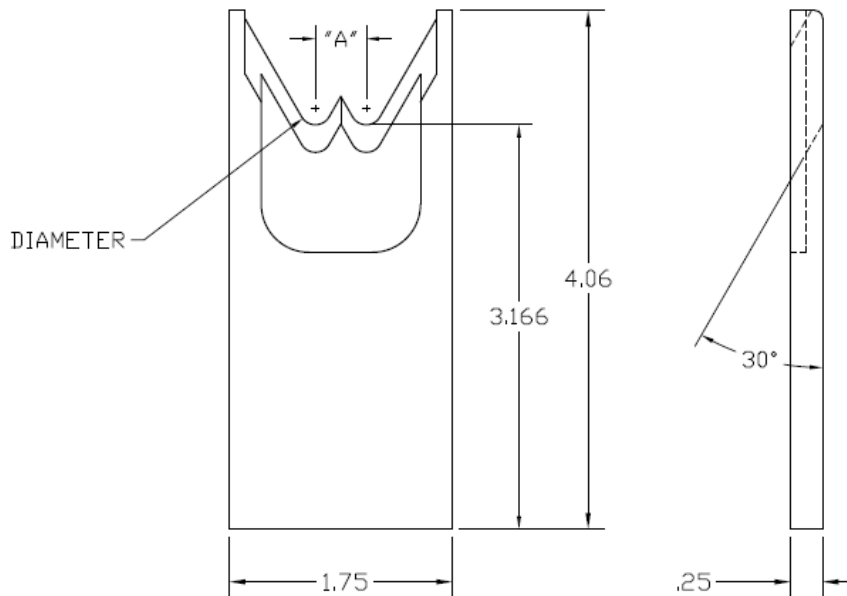

**123723-x** Parallel cord stripping blade

-x	Mark on blade	Qty of "V"s	Diameter inch	"A" dimension inch	Diameter mm	"A" dimension mm
-22	2V-042-125	2	.042	.125	1.07	3.18
-6	2V-052-135	2	.052	.135	1.32	3.43
-2	2V-062-108	2	.062	.108	1.57	2.74
-3	2V-076-120	2	.076	.120	1.93	3.05
-8	2V-076-170	2	.076	.170	1.93	4.32
-7	2V-096-195	2	.096	.195	2.44	4.95
-18	2V-096-225	2	.096	.225	2.44	5.72
-9	2V-120-205	2	.120	.205	3.05	5.21
-19	2V-120-240	2	.120	.240	3.05	6.10

-10	2V-156-325	2	.156	.325	3.96	8.26
-15	2V-156-360	2	.156	.360	3.96	9.14
-25	2V-160-410	2	.160	.410	4.06	10.41
-4	2V-172-325	2	.172	.325	4.37	8.26
-11	2V-172-365	2	.172	.365	4.37	9.27
-12	2V-210-385	2	.210	.385	5.33	9.78
-26	2V-210-415	2	.210	.415	5.33	10.54
-20	2V-225-350	2	.225	.350	5.72	8.89
-1	2V-250-400	2	.250	.400	6.35	10.16
-13	2V-250-420	2	.250	.420	6.35	10.67
-30	2V-255-220	2	.255	.220	6.48	5.59
-29	2V-255-455	2	.255	.455	6.48	11.56
-21	2V-270-410	2	.270	.410	6.86	10.41
-17	2V-280-460	2	.280	.460	7.11	11.68
-16	2V-280-485	2	.280	.485	7.11	12.32
-27	2V-295-480	2	.148	.480	3.76	12.19
-23	2V-312-610	2	.312	.610	7.92	15.49
-31	2V-325-500	2	.325	.500	8.26	12.70
-5	2V-350-530	2	.350	.530	8.89	13.46
-28	2V-380-625	2	.380	.625	9.65	15.88
-14	3V-062-105	3	.062	.105	1.57	2.67
-24	3V-096-156	3	.096	.156	2.44	3.96

### ***Oval strip blades***

This type of blade is for stripping the outer jacket off of a flat multi-conductor cord. Typically each different type of cord needs a different blade size. Contact the Artos sales department for information on how to submit a sample wire for blade sizing and design.

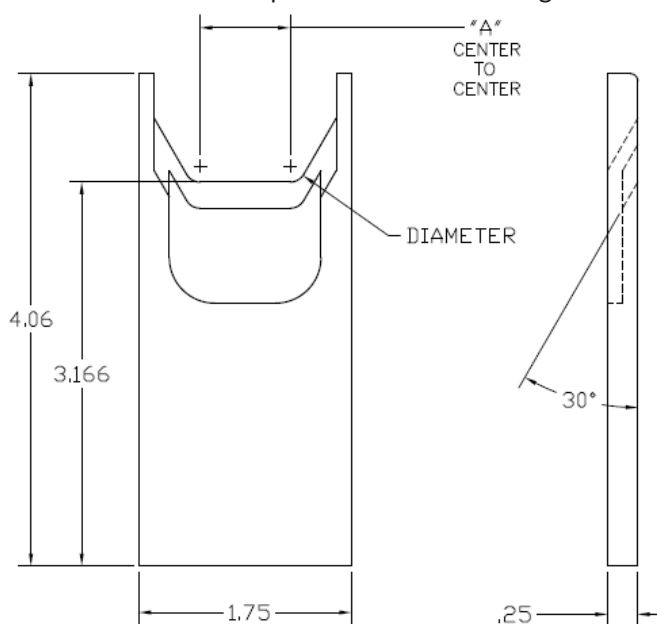

**123758-x** Oval cord stripping blade

-x	Diameter inch	"A" dimension inch	Diameter mm	"A" dimension mm
-12	.080	.735	2.03	18.67
-11	.080	1.130	2.03	28.70
-4	.130	.117	3.30	2.97
-1	.130	.367	3.30	9.32
-13	.140	.265	3.56	6.73
-10	.150	.150	3.81	3.81
-9	.150	.290	3.81	7.37
-8	.180	.330	4.57	8.38
-7	.200	.385	5.08	9.78
-2	.208	.601	5.28	15.27
-3	.260	.742	6.60	18.85
-5	.290	.572	7.37	14.53
-6	.330	.630	8.38	16.00