

ARTOS

ENGINEERING COMPANY

Machine Model	LTC-2 Loose Terminal Crimper	Owners Manual		
PN	6-119932	Rev. 1.00	Date	09 Sept 2016



Artos Engineering Company
21605 Gateway Ct.
Brookfield, WI 53045
Phone 262 252-4545 Fax 262 252-4544
www.artosnet.com
service@artosnet.com

Contents

SAFTY.....	3
Basic instructions	3
Symbols	3
Dangers posed by the machine	3
Correct use of the device	4
Danger sources	4
Work places.....	4
Protective devices	4
Authorised operators.....	5
Guarantee	5
DESCRIPTIONS.....	6
Scope of delivery.....	6
Use	6
Crimp dies	6
Operating components - overview	7
Operating components – function.....	8
STARTUP.....	10
OPERATION One-step crimping.....	16
Two-step crimping	17
FAULTS	19
Error lights	19
Ready does not light or LTC-2 cannot be switched on.....	21
SPARES	22
TECHNICAL DATA	23
EC CONFORMITY DECLARATIONS	24
ACCESSORIES.....	25

SAFTY

Basic instructions

The basic prerequisite for safe handling and trouble-free operation of the LTC-2 is being familiar with and observing the safety instructions.

It is for your own safety!

The safety instructions must be observed by **all** persons working with the LTC-2.

In addition, the rules and regulations pertaining to the application site, particularly those concerning the prevention of accidents, must be observed.

Symbols

The following symbols are used in this operating manual:



indicates a possible **danger of accident or injury** or possible **damage** to the LTC-2.



indicates **instructions for use**.

Dangers posed by the machine

The LTC-2 has been designed according to recognised technical safety rules and has been subjected to safety testing and acceptance.

It is equipped with protection devices.

Nevertheless, in the event of operating errors or misuse there is a danger to

- the life and limb of the operator,
- the machine.

The LTC-2 may only be used

- for the purpose for which it was intended and
- in a perfectly safe technical condition.

All persons involved in the start-up, operation and maintenance of the LTC-2 must

- be appropriately qualified and
- be intimately familiar with this operating manual.

Correct use of the device

The LTC-2 is designed exclusively for crimping work.

Only crimp dies with the matching cross sections according to the **company supplementary sheet** may be used.

Never insert solid metal parts or similar objects; this would destroy the crimp die.

Unauthorised conversions which go beyond mere retooling and modifications to the LTC-2 are prohibited for safety reasons!

! **Correct use of the instrument includes observation of all the instructions and the prescribed operating conditions.**

Danger sources

The LTC-2 may only be operated with the protective cover fitted.

The mains plug must be pulled out prior to doing any work which entails removing the protective cover (e.g. adjusting the die). The device should be switched off at the mains switch during breaks and when not in use.

Work places

The following places should be avoided for operation and storage:

- damp or dusty places,
- places exposed to high temperatures, direct sunlight or low temperatures (operating range: 10°C to 40 °C).

Do not spill liquids onto the LTC-2.

Do not expose the LTC-2 to strong vibrations and impact.

Protective devices

The LTC-2 is switched off by

- the mains switch (0 pressed, LED  dark).
- pulling out the mains plug.
- pulling off the protective cover.

The protective cover is fitted for the operator's safety. It may on no account be modified, removed or bypassed by conversions.

A sign on the bottom of the instrument warns of potential dangers.



Authorised operators

Only authorised and instructed operators may be allowed to work on the LTC-2.

The operator is responsible for third persons within the working area.

The owner must

- give the operator access to the operating manual and
- make sure that the operator has read and understood it.

Guarantee

Our “General Terms of Sale and Delivery” apply basically. These will be available to the owner at the latest upon signing the contract.

Guarantee and liability claims are excluded in the case of personal injury and property damage in the event of violation of the following points:

- use of the LTC-2 for a purpose for which it was not intended
- improper work places
- improper use and use above and beyond that described in the operating manual
- unauthorised constructional modifications to the LTC-2
- continued operation of the LTC-2 after faults have been detected
- continued operation of the LTC-2 beyond 500,000 crimping processes. The device must be serviced by the manufacturer after 500,000 crimping processes. A LED  on the control panel signals when the device is due for servicing.
- improperly performed die assembly/repairs.

! Only use original dies and spares.

DESCRIPTIONS

Scope of delivery

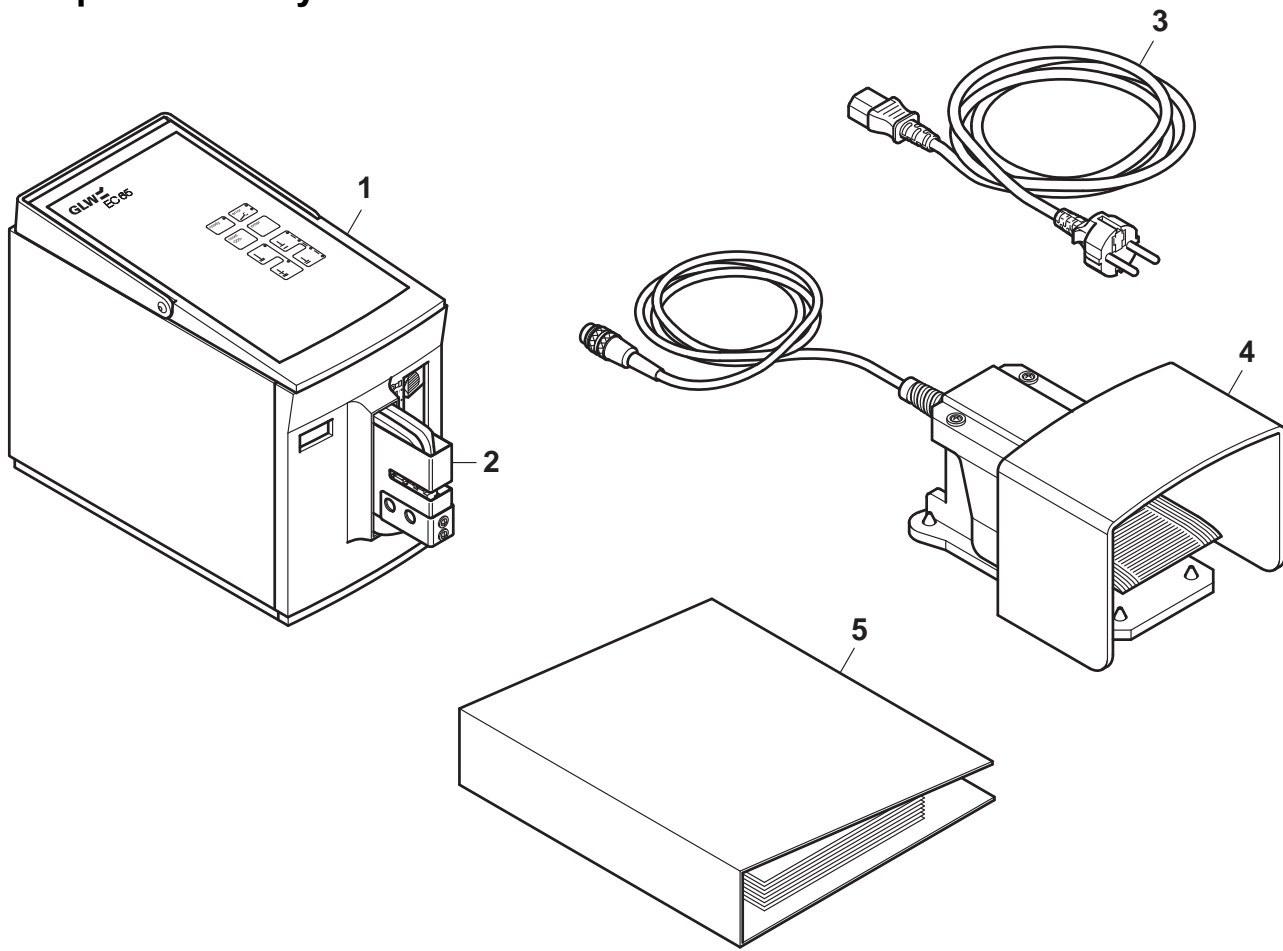

Figure 1 Scope of delivery

1	Basic device LTC-2	1 pc.	4	Foot switch	1 pc.
2	Protective cover	1 pc.	5	Operating Manual	1 pc.
3	Line cord	1 pc.			

Use

The electric crimper LTC-2 is used for pressing crimp contacts.

By using different crimp dies crimp contacts of various kinds can be processed within a wide range of cross sections. This wide range and short cycle times (< 1 s) make the LTC-2 equally suitable for use in workshops and in complex cable assembly systems.

Crimp dies

The available crimp dies are listed in the company supplementary sheets. Every crimp die is assigned a protective cover with an exactly fitting insertion slit.

Operating components - overview

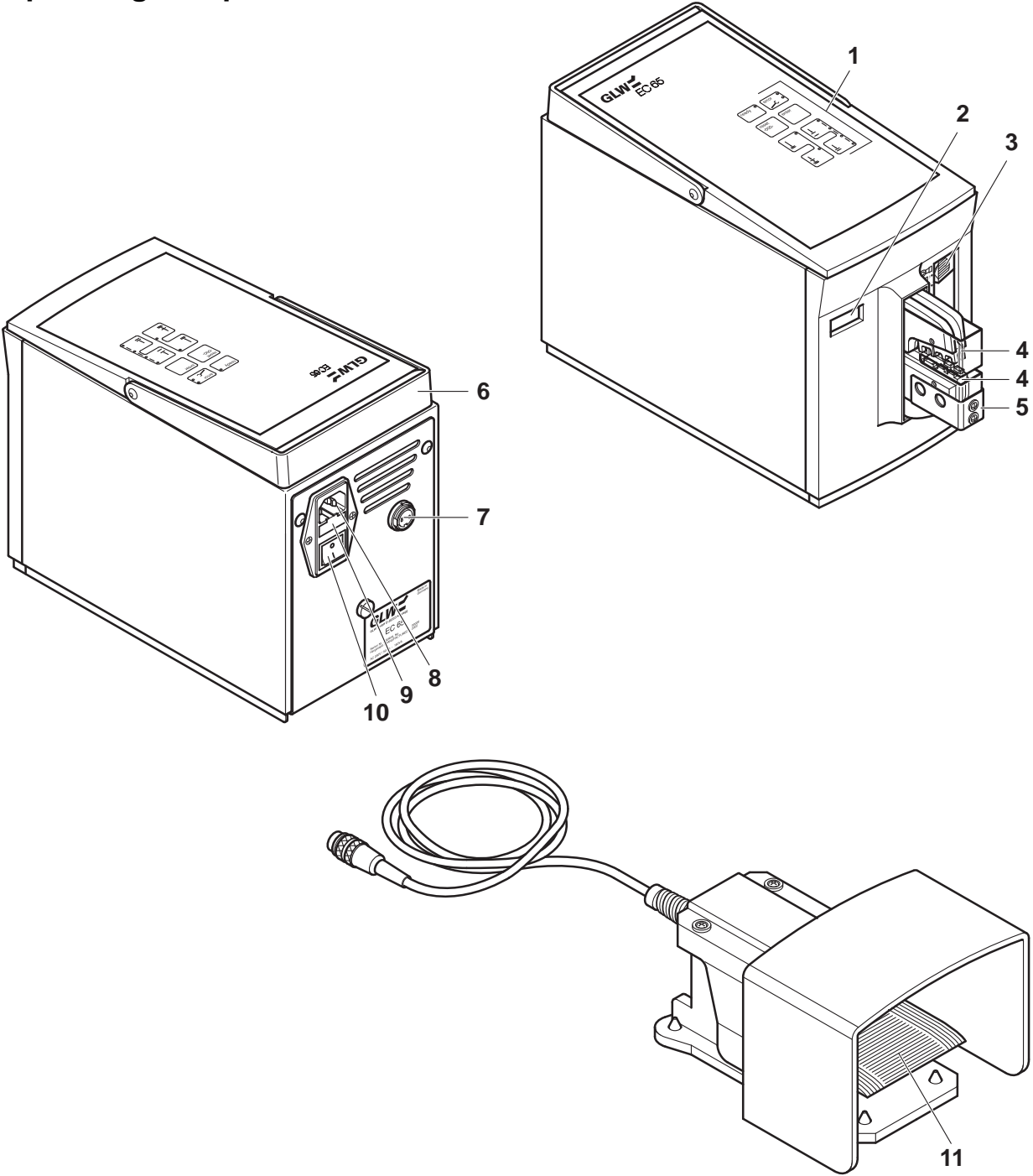









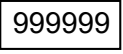

Figure 2 Operating components

- | | | | |
|---|-----------------------------|----|------------------------|
| 1 | Control panel | 7 | Connection foot switch |
| 2 | Piece counter | 8 | Mains connection |
| 3 | Force range adjusting slide | 9 | Mains fuses |
| 4 | Crimp die | 10 | Power switch |
| 5 | Protective cover | 11 | Foot switch |
| 6 | Handle | | |

Operating components – function

1 Control panel		Serves to select operating functions and display device states
LED-ready		indicates standby state
LED-error		indicates a preceding defective crimping or fault (a new crimping cannot be triggered as long as the LED is alight)
LED-service		indicates that the LTC-2 is due for servicing (to guarantee consistent quality of the crimpings, the instrument must be serviced by the manufacturer after 500,000 crimpings).
Reset button		Sets the piece counter reading back to 0 when the LTC-2 is switched on.
Enter button		Extinguishes the LED  . The LTC-2 is ready.
Mode 1 button		Switches the LTC-2 to mode 1 (LED lights). Crimping takes place in one step in mode 1. The crimp die is fully closed and reopened by pressing the foot switch.
Mode 2 button		Switches the LTC-2 to mode 2 (LED lights). Crimping takes place in two steps in mode 2. The crimp contact is clamped in the crimp die but not crimped by pressing the foot switch. The wire can now be inserted in the crimp contact. The crimp die is fully closed and reopened by pressing the foot switch a second time.
Opening limit buttons		<p>The opening of the crimp die can be changed by pressing the upper (open) and lower (close) button. The LEDs indicate the opening:</p> <ul style="list-style-type: none"> • 4 LEDs alight: max. opening • no LEDs alight: min. opening <p>Resetting only becomes active after the next crimping.</p>
2 Piece counter		The counter records every completed crimping process. Crimpings aborted due to faults are not recorded. The counter reading is stored for about 1 week when the device is switched off.

3 Force range adjusting slide



The range in which the crimp die is pressed together with full force can be set with this slide. If the die meets with an obstruction outside this range, the crimping die open immediately to avoid damage to the die or to the falsely inserted material.

- Position 1: min. force range
- Position 5: max. force range

4 Crimp die

Positions the crimp contact and presses this together with the wire.

It consists of the top and bottom die. These can be changed depending on the application.

5 Protective cover

Prevents injury to fingers and hands in the danger area of the crimp die.

The LTC-2 only works when the protective cover is fully inserted.

6 Handle

Serves for transporting the LTC-2.

7 Connection foot switch

Device connection for the foot switch.

8 Mains connection

Device connection for the power cable.

9 Mains fuses

Fine fuses (2x) integrated in the mains connection.

10 Power switch

Switches on the power supply (I pressed) or off (0 pressed). The LED  on the **control panel** lights up after switching on.

11 Foot switch

Pressing the foot switch triggers the crimping process.

The foot switch must be kept pressed until the crimp die is fully closed (mode 1) or the crimp contact is clamped (mode 2).

If the LED  lights up on the **control panel** the crimping process cannot be triggered.

STARTUP

1. Selecting the installation site

- The installation site must be level and horizontal.

! The conditions in the **SAFETY** chapter under **Work Places** must be observed.

2. Removing the protective cover

- Unscrew the screw (1).
- Pull off the protective cover (2).

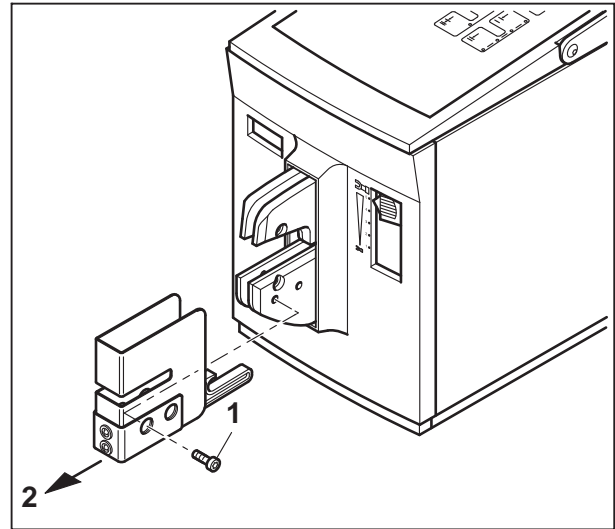

Figure 3 Removing the protective cover

3. Mounting the crimp die

! **Note installation position:**
Small cross section at front.
Large cross section at back.

- Insert bottom die (1).
- Screw in screw (2) **loosely**.
- Insert top die (3).
- Screw in screw (4) **loosely**.

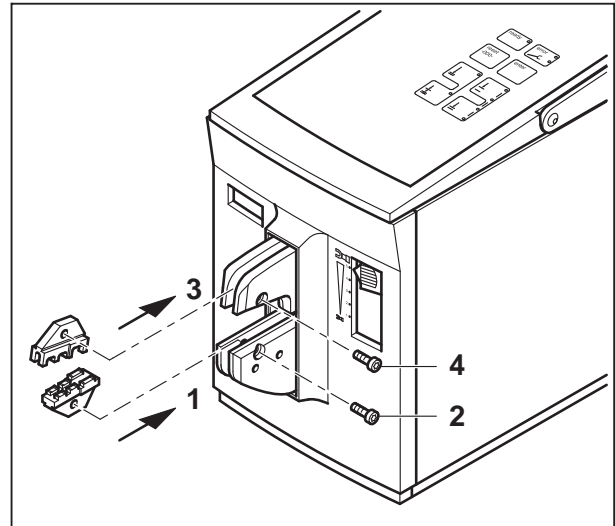

Figure 4 Mounting the crimp die

4. Mounting the protective cover

- Insert the safety pin (1) in the bottom die and push in the protective cover (2) until you can feel it snap in.



The power supply to the LTC-2 will be cut off if the protective cover is not fitted or is not fitted properly.

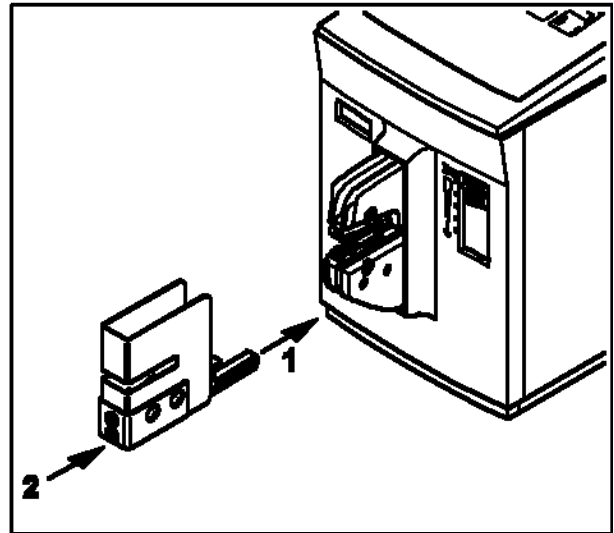



Figure 5 Mounting the protective cover

5. Connecting / switching on the LTC-2

- Connect the foot switch (1) to the foot switch connection.
- Connect the mains plug (2) on the mains connection and the shock-proof plug (3) to the mains socket.
- Switch on the LTC-2 at the mains switch (4) (press I).
-  lights up (5).

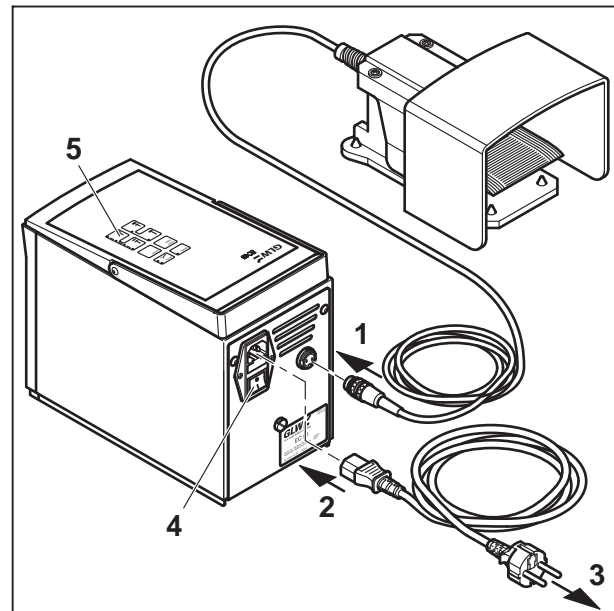

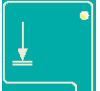



Figure 6 Connecting / switching on the LTC-2

6. Centring the dies

! Since the bores of the dies have a slight clearance to the fastening screws it is possible to offset the dies to each other.

Centring / adjustment of the dies is possible with the following adjustment mode (steps 6 and 7).

- Press  +  simultaneously (1).
-  +  flash (2).
- Push force range adjusting slide (3) to position 1.
- Press the foot switch (4) and keep it pressed.
- The crimp die (5) closes slowly until it meets with a resistance and centres itself.
- Release the foot switch (6).

! If the foot switch is released before the crimp die is closed, this opens automatically, the adjustment mode is ended and  lights.

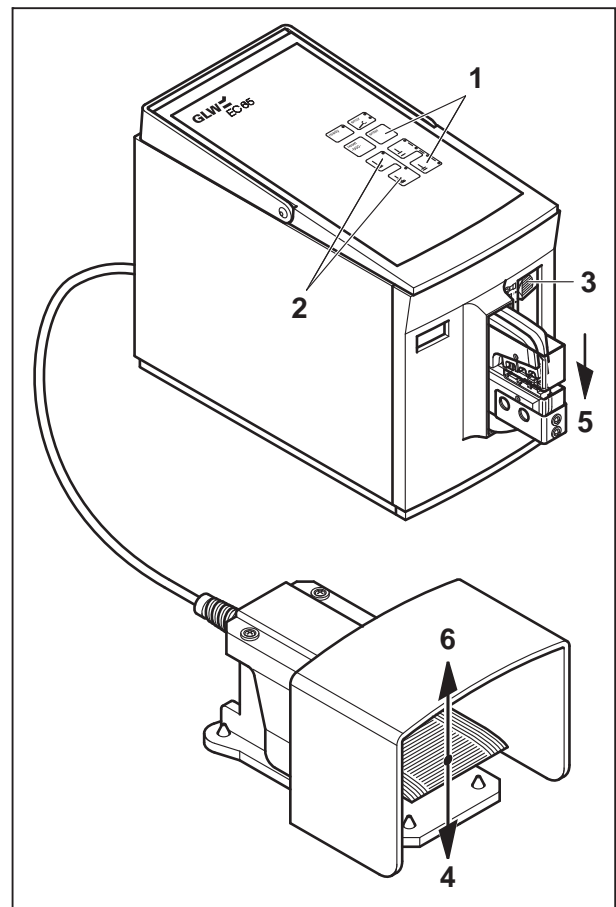



Figure 7 Centring the dies

7. Adjusting the dies

 **The protective cover must be pulled off, pull out the mains plug!**

Switch off the LTC-2 at the power switch (1) (press 0).

Pull out the mains plug (2).

Pull off the protective cover (3).

Check the centring of the dies, adjust if necessary (4).

Tighten the screw (5).

Push on the protective cover (6) and tighten the screw (7).

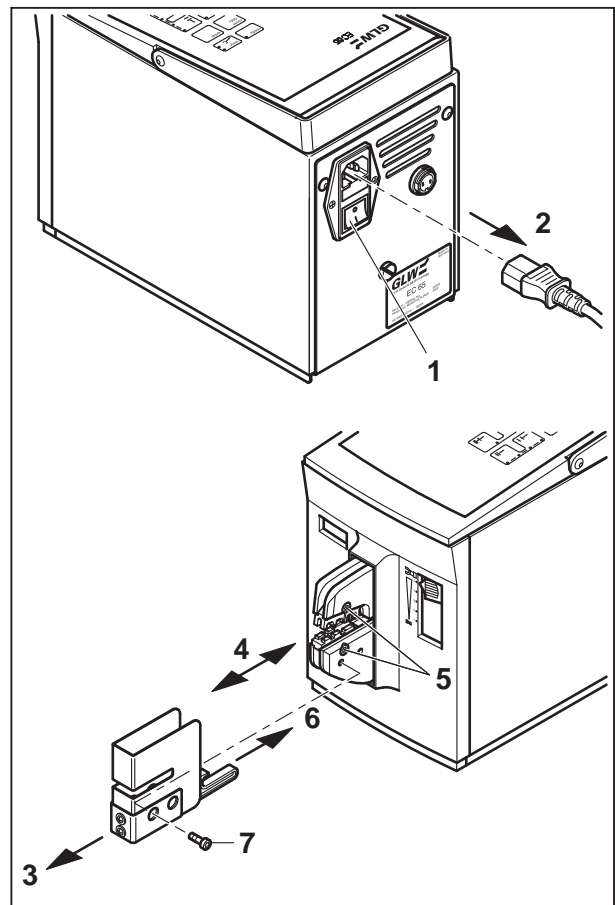

Figure 8 Adjusting the dies

8. Getting the device ready

Connect the mains plug (1).

Switch on the power switch (2) (press I).

 lights up (3).

Press the foot switch (4).

The crimp die (5) opens automatically, the foot switch (6) can be released.

 lights up (7).

Press  (8).

The device is ready.

! **Mode 2**  **is set.**
Check mode before using.

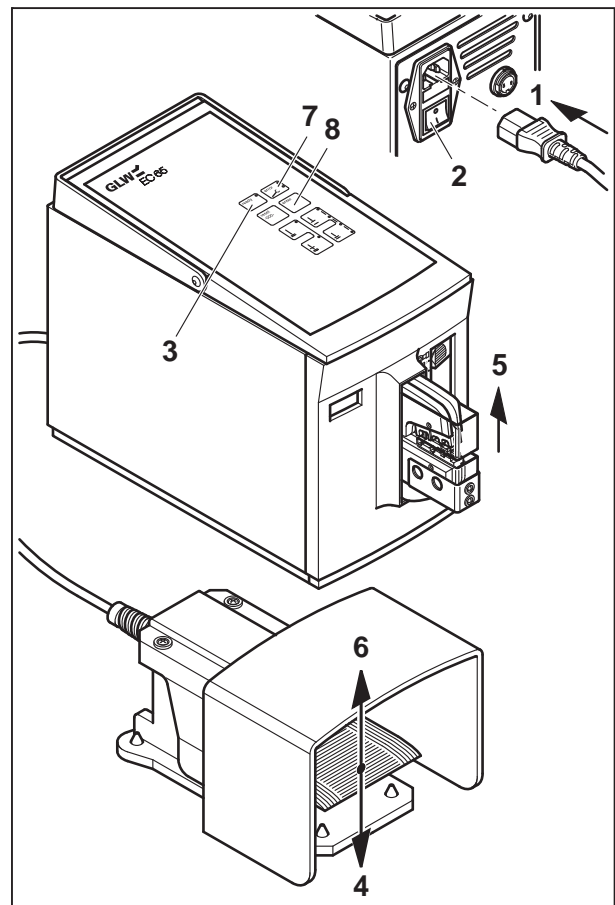

Figure 9 Getting the device ready

9. Set optimum force range



Push force range adjusting slide to position 1.

 Set mode 1.

Perform crimping without crimp contact inserted by pressing the foot switch.

If  lights up, check the adjustment of the dies (see steps 6 and 7).

Perform crimping with wire and crimp contact inserted.

! **Pay attention to correct cross section according to the company supplementary sheet.**

If  lights up, push up the slide one step and press



Repeat until  no longer lights.

To compensate for any material tolerances, push the setting slide up another step.

10. Set the optimum opening distance



Press the top button until all 4 LEDs light up. The maximum opening distance is set.

Perform crimping.





Changes in the setting only become effective after the next crimping process.

If the opening distance is too large press the bottom button (3 LEDs light up) and perform a new crimping.

Repeat the process until the optimum opening distance is set.

OPERATION One-step crimping

1. Set mode 1

- Switch on the LTC-2 at the power switch (1) (press I).
-  lights up (2).
-  Set mode 1 (3).
- Read counter (4) if necessary and reset to 0 with  (5).

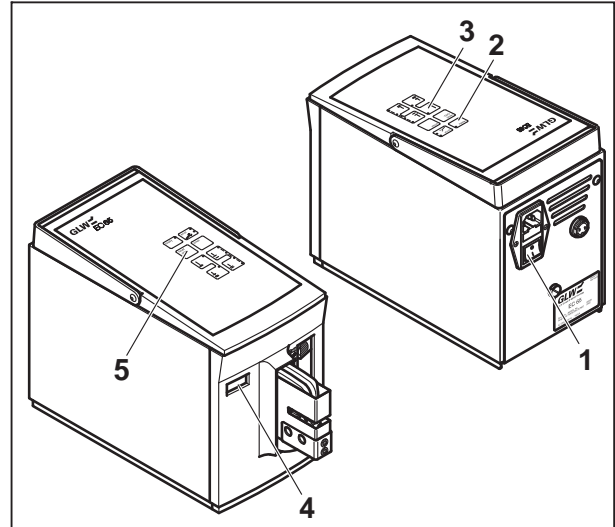

Figure 10 Set mode 1

2. Crimp, crimp contact

Centre the crimp contact (1) on the bottom die.

Insert wire (2) in the crimp contact.

! Pay attention to correct cross section according to the company supplementary sheet.

Press the foot switch (3) until the crimp die is fully closed (4).

The crimp die (5) opens automatically, the foot switch (6) can be released.

Remove the crimp contact with crimped wire (7).

!  lights up in the case of defective crimping. Consult the FAULTS chapter.

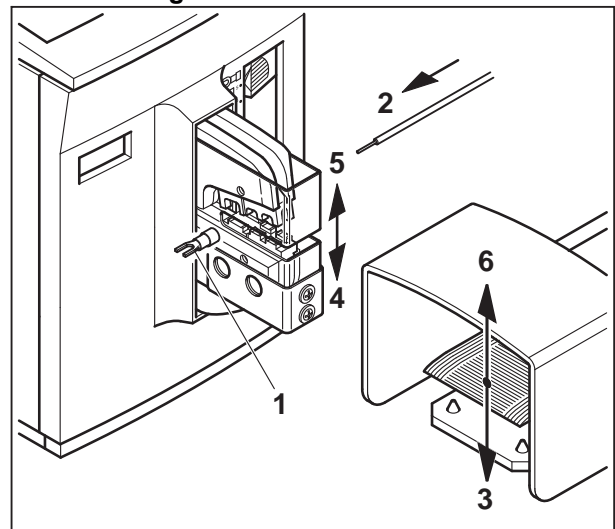

Figure 11 Crimp crimp contact

3. Taking out of operation

Read counter (1) if necessary.

Switch off the LTC-2 at the power switch (2) (press 0).

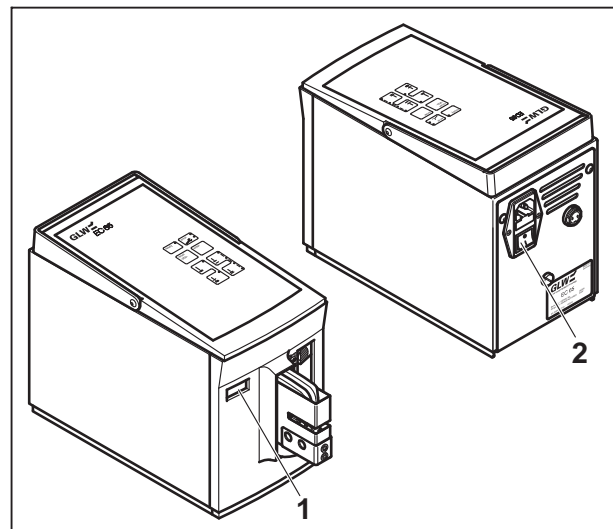





Figure 12 Taking out of operation

Two-step crimping

1. Set mode 2

- Switch on the LTC-2 at the power switch (1) (press I).
-  lights up (2).
-  Set mode 2 (3).
- Read counter (4) if necessary and reset to 0 with  (5).

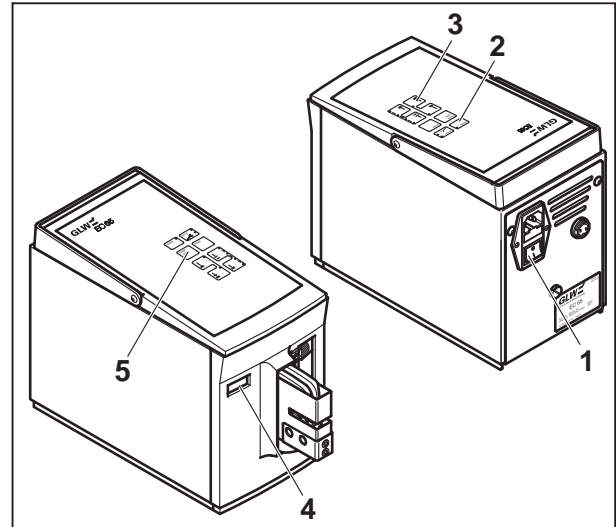

Figure 13 Set mode 2

2. Clamp crimp contact

Centre the crimp contact (1) on the bottom die.

! Pay attention to correct cross section according to the company supplementary sheet.

Press the foot switch (2) until the crimp contact is clamped (3).

Release the foot switch (4).

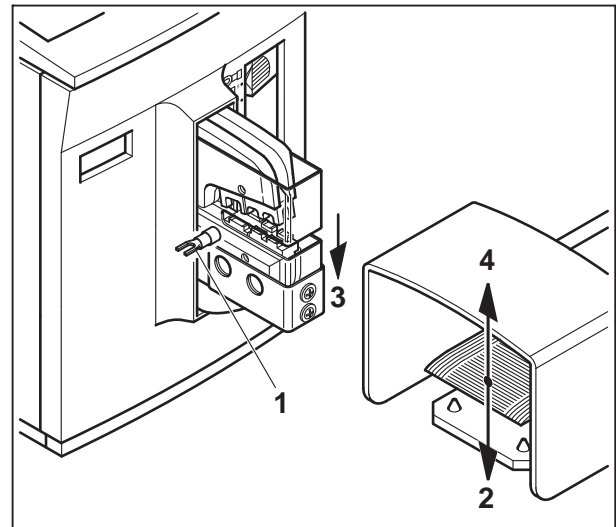

Figure 14 Clamp crimp contact

3. Crimp crimp contact

Insert wire (1) in the crimp contact.

Press the foot switch (2) until the crimp die is fully closed (3).

The crimp die (4) opens automatically, the foot switch (5) can be released.

Remove the crimp contact with crimped wire (6).

!  lights up in the case of defective crimping. Consult the **FAULTS** chapter.

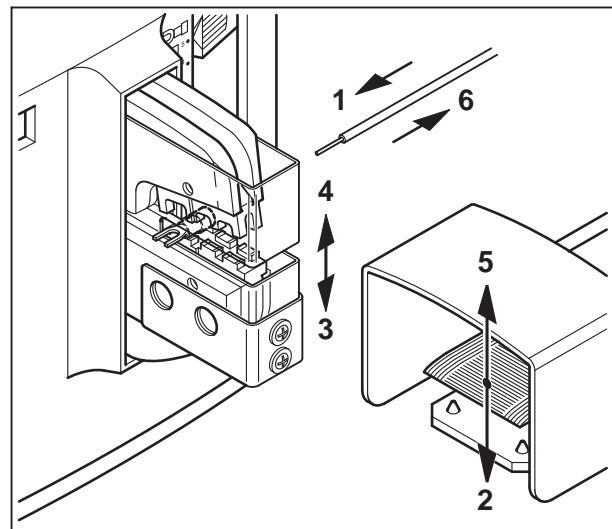

Figure 15 Crimp crimp contact

4. Taking out of operation

Read counter (1) if necessary.

Switch off the LTC-2 at the power switch (2) (press 0).

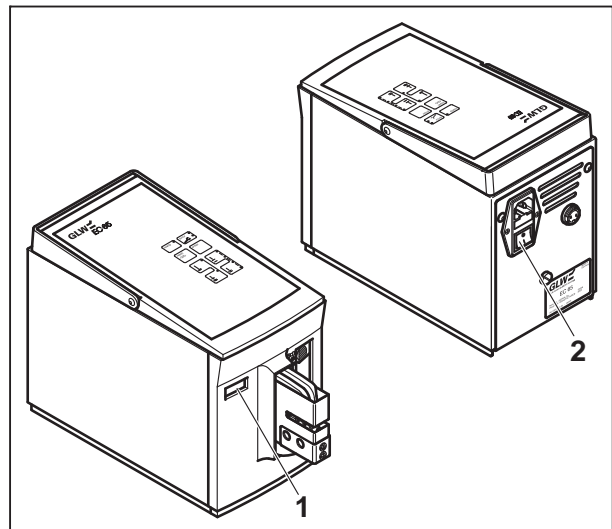

Figure 16 Putting out of operation

FAULTS

Error lights

This fault may be caused by:

1. Foot switch released too early

The crimp die opens immediately to the initial position when the foot switch is released too early.

Press .

 goes out.

Repeat crimping.

2. Wrong cross section chosen.

When inserting a too large crimp contact or other unsuitable objects the crimping process is aborted due to overloading and the crimp die opens immediately to the initial position.

Press .

 goes out.

Repeat crimping with the right cross section according to the company supplementary sheet.

3. Incorrectly set force range

If the resistance reached in the crimping process exceeds the range set on the force range adjusting slide, the crimp die opens immediately to the initial position.



Push the force range adjusting slide up one step.

Press .

 goes out.

Repeat the crimping process until the optimum force range is set.

4. Dies not adjusted correctly



The protective cover must be pulled off, pull out the mains plug!

- Switch off the LTC-2 at the power switch (1) (press 0).
- Pull out the mains plug (2).

Unscrew the screw (3).

Pull off the protective cover (4).

Loosen the screws (5).

Perform steps 4 to 10 of the **START-UP**.

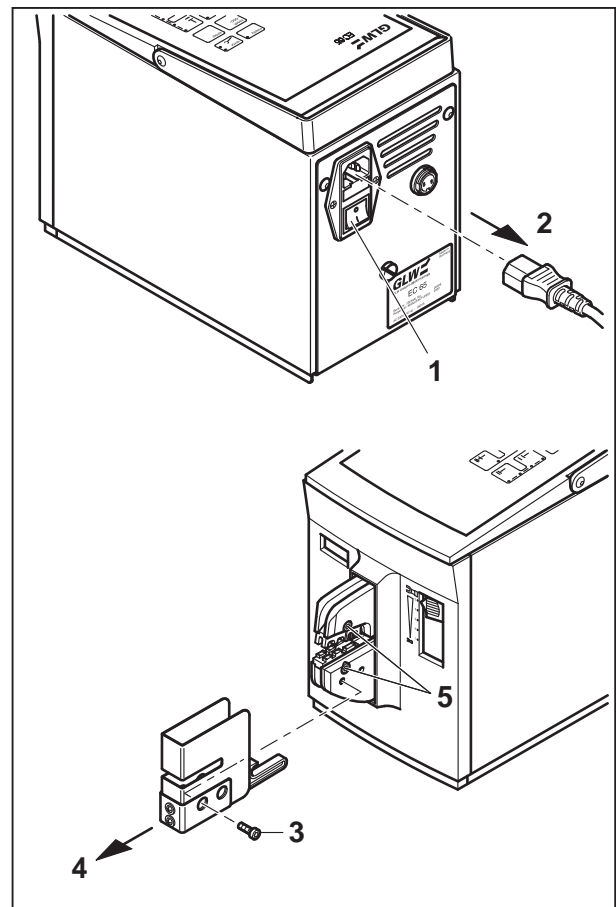

Figure 17 **Loosen dies**



Ready does not light or LTC-2 cannot be switched on

This fault may be caused by:

1. No mains connection

Check whether the mains plug at the mains connection of the LTC-2 and the shock-proof plug are connected to the mains socket.

Make sure that the power supply at the mains socket is okay.

2. Mains fuse defective

 **The mains connection must be opened, pull out the mains plug!**

Switch off the LTC-2 at the power switch (1) (press 0).

Pull out the main plug (2).

Pull out the fuse holder (3).

Check the main fuses (4).

Replace the mains fuse (see **SPARES** chapter for part numbers).

Push in the fuse holder.

! **The fuse holder must snap in.**

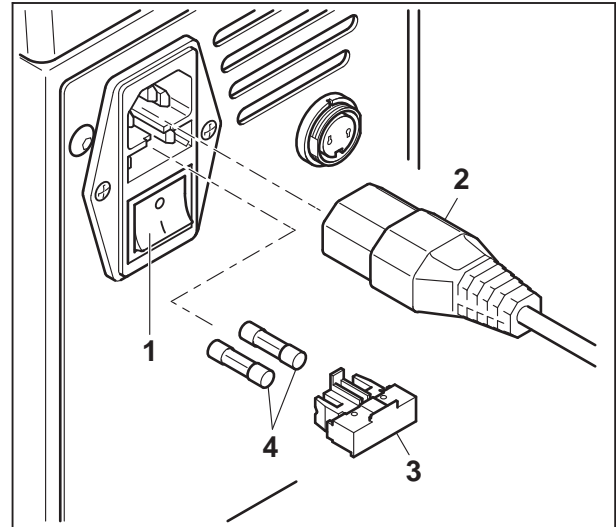
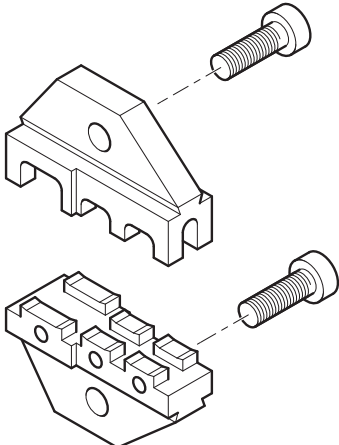
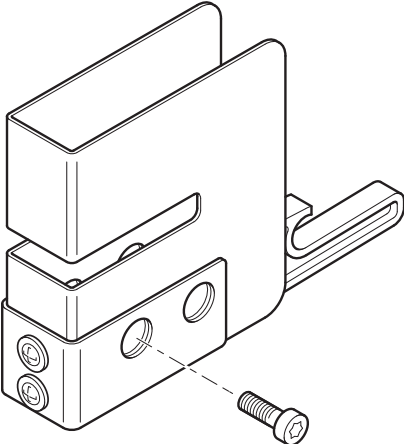
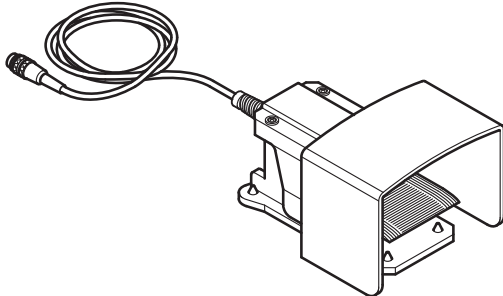
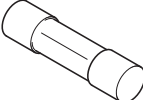

Figure 18 Check the mains fuse

SPARES The spares listed below can be ordered by specifying the appropriate part numbers.

Part	Part no.	Quantity
<p style="text-align: center;">Dies</p> 	<p>see company supplementary sheet</p>	
<p style="text-align: center;">Protective cover</p> 	<p>see company supplementary sheet</p>	
<p style="text-align: center;">Foot switch</p> 	<p>LT2-EC60001</p>	<p>1 pc.</p>
<p>Mains fuse 230V T1.25A Mains fuse 115V T2.50A</p> 	<p>ES-CS0006 ES-CS0007</p>	<p>2 pcs.</p>

TECHNICAL DATA

Mains connection.....	230 V / 50 Hz (115 V / 60 Hz)
Power consumption	160 VA
Max. pressing force	10 kN
Pressing time	< 1 s
Counter	6-digit LCD, resettable
Dimensions (W x H x D)	140 x 220 x 320 mm
Weight of basic device.....	10 kg
Weight of foot switch.....	1.2 kg
Acoustic pressure emissions L _{pA}	< 70 dB (A)

Rating plate

Manufacturer		Made in
Manufacturer address		Made in
Machine type		Serial number
		Year
Main connection		Power consumption 230V/50Hz (115V/60Hz)

EC CONFORMITY DECLARATIONS

Manufacturer: GLW GmbH
Address: Steinbeisstrasse 2
88353 Kisslegg
Germany

We hereby declare that the machine described below complies with the pertinent basic safety and health requirements of the EC machine directive in design and construction and version marketed by us. This declaration will lose its validity in the case of modifications to the machine which are not approved by us.

Name of the equipment: **Crimping machine for crimp contacts**

Machine type: **LTC-2**
LTC-2 US (115 V)



Pertinent EG-Guidance: **EG- Machine directive 2006/42/EG**
EG- Low-voltage directive 2006/95/EG
EG- Directive Electromagnetic Compatibility 2004/108/EG

Applied harmonised standards: **DIN EN ISO 12100-1 and -2:2004**
DIN EN ISO 13857:2008
DIN EN 349:2008
DIN EN 60204-1:2006
DIN EN 50081-1:1993
DIN EN 50082-2:1994

Place, date: Kisslegg, 16. March 2016

Legally binding signature: 

Information about signatory: Bruno Weiland

Responsible person for Documents: Bruno Weiland

ACCESSORIES

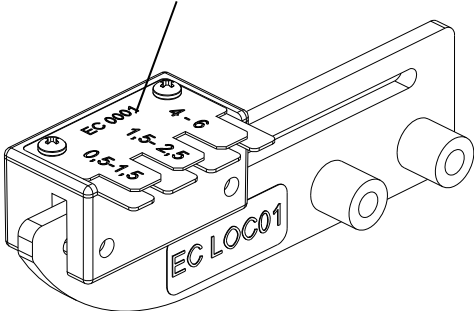
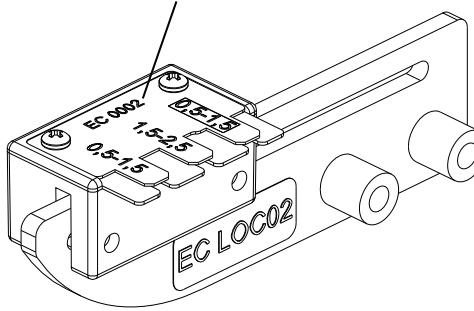
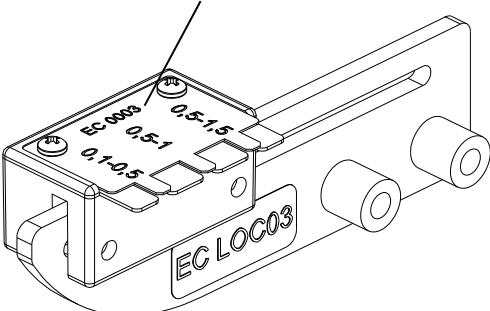
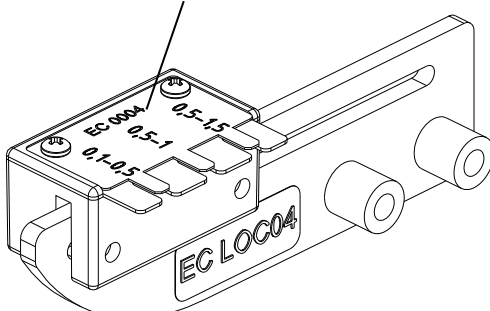
Locator	
<p>Item No. LT2-ECLOC01 suitable for:</p> <ul style="list-style-type: none"> > Female Terminals 6,3 DIN 46247 > Die LT2-ECR0560 > Protective Cover LT2-ECPC02 <p>Spare part: Locator plate Item No. LT2-EC0001</p> 	<p>Item No. LT2-ECLOC02 suitable for:</p> <ul style="list-style-type: none"> > Female Terminals 4,8 DIN 46247 > Dies LT2-ECR0115; LT2-ECR0560 > Protective Cover LT2-ECPC02 <p>Spare part: Locator plate Item No. LT2-EC0002</p> 
<p>Item No. LT2-ECLOC03 suitable for:</p> <ul style="list-style-type: none"> > Female Terminals 2,8x5 DIN 4624 > Dies LT2-ECR0115; > Protective Cover LT2-ECPC02 <p>Spare part: Locator plate Item No. LT2-EC0003</p> 	<p>Item No. LT2-ECLOC04 suitable for:</p> <ul style="list-style-type: none"> > Female Terminals 2,8x6 DIN 46247 > Dies LT2-ECR0115; > Protective Cover LT2-ECPC02 <p>Spare part: Locator plate Item No. LT2-EC0004</p> 

Item No. LT2-ECLOC05 suitable for:

- > Male Terminals 6,3 DIN 46247
 - > Dies LT2-ECR0560
 - > Protective Cover LT2-ECPC02
- Spare part: Locator plate Item No. LT2-EC0005

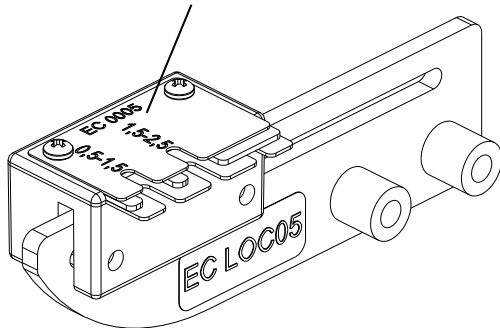

Item No. LT2-ECLOC06 suitable for:

- > Male Terminals 6,3 Typ HN DIN 46247
 - > Dies LT2-ECR0560
 - > Protective Cover LT2-ECPC02
- Spare part: Locator plate Item No. LT2-EC0006

